

Smart 25S

Essential Infrared



Smart Infrared Illuminators

Smart Series IR Illuminators are outdoor IP67 rated, rugged and vandal resistant. Choose from six range/angle options to match the light to the camera's field of view.

Easy Integration and Control

Seamless and precise control via Input/Output ports. Sync with camera, sensors or other system devices with I/O ports. For easy integration, a built-in photocell switches the IR ON/OFF based on lighting conditions.

Lifetime Warranty - Made in the USA

AXTON Lights are covered by a lifetime warranty with advanced replacement.

FEATURES

- Wavelength - 850nm Infrared
- Outdoor IP67 Rated
- Energy Efficient - 25 Watts
- Advanced LED Technology
- I/O Port Sync with Sensors, Devices
- Automatic Day/Night Sensor
- Lifetime Warranty, Made in the USA

RANGE

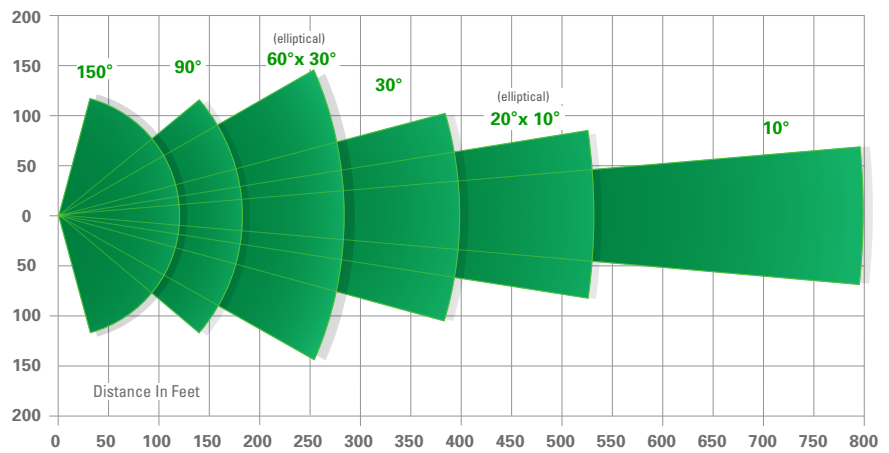

Angle: 150° Range: 120ft / 36m HFOV : 232ft / 70m	Angle: 90° Range: 175ft / 53m HFOV : 225ft / 68m	Angle: 60° x 30° Range: 285ft / 86m HFOV : 285ft / 86m	Angle: 30° Range: 400ft / 122m HFOV : 207ft / 63m	Angle: 20° x 10° Range: 530ft / 161m HFOV : 166ft / 50m	Angle: 10° Range: 800ft / 243m HFOV : 140ft / 42m
--	---	---	--	--	--

SPECIFICATIONS

Wavelength	850nm Infrared
Input Voltage	24 to 36 VDC or 24 VAC
Angle/Range Options:	150°, 90°, 60°x30°, 30°, 20°x10° or 10°
Power Consumption	25 Watts
Operating Temp.	-58° to 140°F / -50° to 60°C
Dimensions	5.25" x 3" x 7.25" / 133 x 76 x 184mm
Weight	3 lbs / 1.3kg
Environmental	Outdoor IP67 Rated
Mounting	Pan/Tilt U Bracket Included

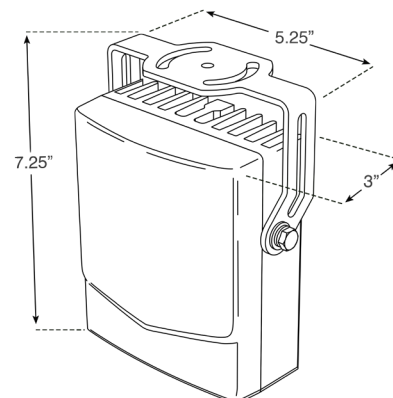

UNIVERSAL SOLUTIONS



801 Robinson Drive, Suite #500, North Salt Lake, UT 84054
Tel: 801/519-0500 • Email: sales@axtontech.com • Website: axtontech.com

